

It is a reality that in many occasions we can not fill a tank or a mixer without a previous cleaning, For the simple fact of not using the same material used previously. Therefore we have designed a high-pressure washing system for the cleaning of machinery. Two types of cleaning can be done; Automatic, by means of pressurized water jets Cycle through rotary or manual heads, in which an operator with a lance is cleaning the inside of the cubicles.

 *Environmentally friendly product, allows the reuse of water.*



Due to its robustness and versatility it allows wide application in the sector of:



**Concrete/Prefabricated
Chemical
Refractory
Chemical fixation/
Environment**

Made for optimal cleaning with multiple rotation by reducer motor

More common application
MIXERS

More common application
TANKS



**Rotary head
RH-400**



**Rotary head
RH-550**

MIXERS

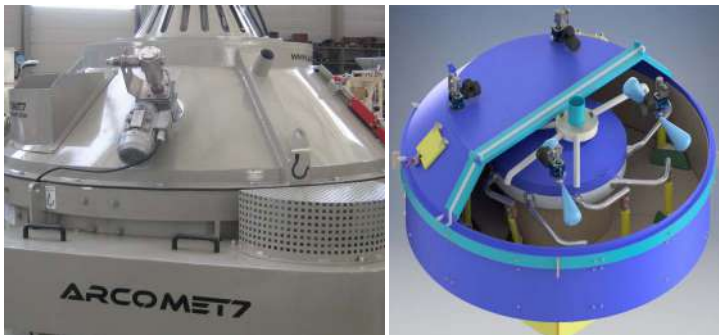

- ✓ Use of cleaning water for the kneading.
- ✓ Saving cleaning times.
- ✓ Increases production capacity.

TANKS



Opción:  ATEX22

- ✓ Increases safety, cleanliness and productivity of tanks and propellers.
- ✓ It reduces maintenance time of and operating costs.
- ✓ Reduces costs in water and chemical use.

MODELOS / CABEZALES

		2	3	4	5	6
VOLUME	L/min	40	40	40	40	40
BOROMETIC PRESSURE	bar.	100	100	100	100	100
SUPPLY PRESSURE	bar.	3-5	3-5	3-5	3-5	3-5
SUPPLY PRESSURE	Kw	11 Kw				
ROTARY HEAD ENGINE	Kw	0.18 Kw				
POWER SUPPLY VOLTAGE	VAC	400 VAC - 50/60 Hz				
ELECTROVALVULES VOLTAGE	VAC	110 VAC (Other tensions)				

MEASUREMENTS



RH-400

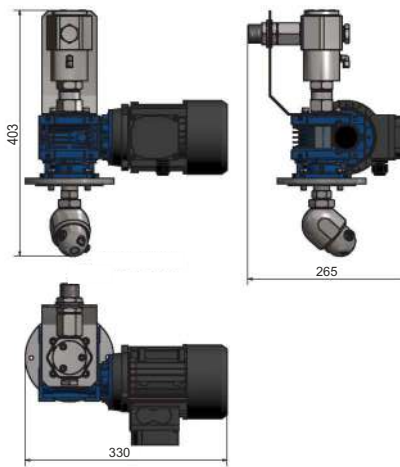

RH-550

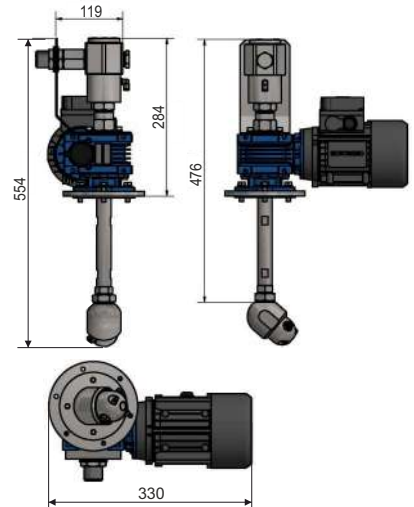

AUTOMATION

AE-9220P.SL equipment designed to control and Monitor the washing system.

- ✓ Allows continuous visualization of the cycle process cleaning.
- ✓ The cycle is perfectly integrated into the operating logic of the installation.



ARCO LAV MIX SOFTWARE

Program to visualize the process of a PC of the washed system.

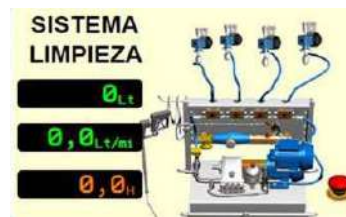

- Features:
- Time control.
 - Alarms.
 - State cleaning system.
 - System cleaning cycle.
 - Control marcha - paro.



Possibility of integration with the software dosage: Arco Gold Two.

DELEGACIÓN ZONA CATALUÑA
Tel. +34 619 70 36 20

DELEGACIÓN ZONA CENTRO
Tel. +34 680 980 628

ARLACO LDA.
Tel. +35.1227128279
www.arlaco.pt

ARCO BRASIL LTDA
Tel. +55.1938882738
www.arco brasil.ind.br

DELEGACIÓN COLOMBIA
Tel. +57.3167588219

DELEGACIÓN ARGENTINA
Tel. +54.0291155353570

Arco Met 7, S.L.
Pol. Ind. Centrovía,
C/ Buenos Aires, N°12 - Nave A
50198 La Muela, Zaragoza (España)
TELF: +34 976 141873
FAX: +34 976 144763